



Cambridge O Level

CANDIDATE
NAME

--

CENTRE
NUMBER

--	--	--	--	--

CANDIDATE
NUMBER

--	--	--	--



COMBINED SCIENCE

5129/21

Paper 2

May/June 2022

2 hours 15 minutes

You must answer on the question paper.

No additional materials are needed.

INSTRUCTIONS

- Answer **all** questions.
- Use a black or dark blue pen. You may use an HB pencil for any diagrams or graphs.
- Write your name, centre number and candidate number in the boxes at the top of the page.
- Write your answer to each question in the space provided.
- Do **not** use an erasable pen or correction fluid.
- Do **not** write on any bar codes.
- You may use a calculator.
- You should show all your working and use appropriate units.

INFORMATION

- The total mark for this paper is 100.
- The number of marks for each question or part question is shown in brackets [].
- The Periodic Table is printed in the question paper.

This document has **24** pages. Any blank pages are indicated.

1 Different foods contain different amounts of carbohydrate, fat, fibre, protein and water.

Fig. 1.1 shows the percentage composition of five foods.

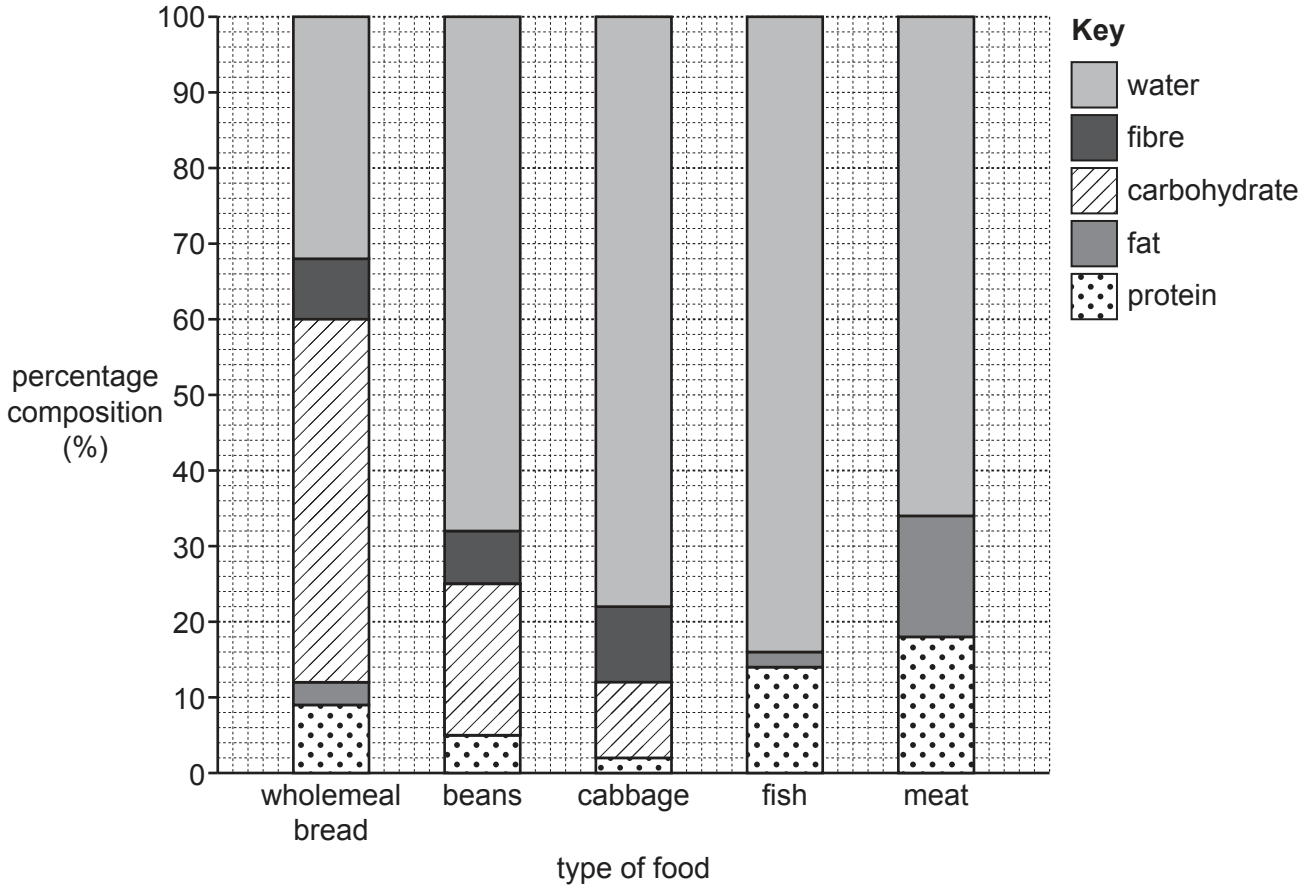

Fig. 1.1

(a) Use the information in Fig. 1.1 to:

(i) Identify two foods that contain **no** fat

..... and [1]

(ii) Identify the food that contains 20% carbohydrate [1]

(iii) Determine the percentage composition of protein in meat. % [1]

(b) State the importance of fibre (roughage) in the diet.

.....
 [1]

(c) Explain how a balanced diet varies according to the age and activity of an individual.

.....

.....

.....

.....

.....

..... [2]

[Total: 6]

- 2 When a mixture of aluminium and iron(III) oxide is heated, a reaction occurs.

The equation for the reaction is:

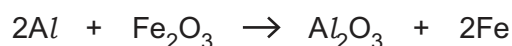

The relative molecular mass of iron(III) oxide is 160.

[A_r: Al, 27; Fe, 56; O, 16]

- (a) (i) Calculate the relative molecular mass of aluminium oxide.

..... [1]

- (ii) Complete the following sentences.

540 g of aluminium produces g of aluminium oxide and g of iron.

540 g of aluminium reacts with g of iron(III) oxide.

[3]

- (b) State **one** use of aluminium metal.

Explain why aluminium has this use.

use

explanation

..... [2]

[Total: 6]

3 Fig. 3.1 shows the front of a human eye as seen in normal daylight.

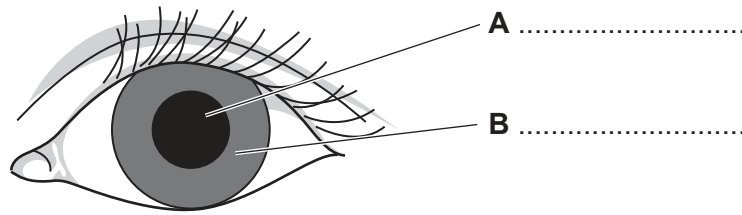

Fig. 3.1

(a) (i) Label structures **A** and **B** on Fig. 3.1. [2]

(ii) A bright light is now shone into the eye shown in Fig. 3.1.

Complete Fig. 3.2 to show how structures **A** and **B** appear when bright light is shone into the eye.

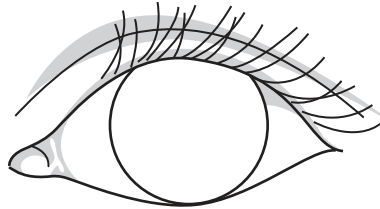

Fig. 3.2

[2]

(b) Complete the sentences about hormones by inserting words from the list.

Each word may be used once, more than once or not at all.

blood **capillaries** **excretory** **gland**
kidney **liver** **muscle** **target**

A hormone is defined as a chemical substance produced by a

A hormone is transported around the body by the and alters the activity of one or more organs.

Hormones are destroyed by the

[4]

[Total: 8]

4 A vernier caliper is used to measure the diameter of a bolt thread, as shown in Fig. 4.1.

The bolt thread is the part of the bolt above the bolt head.

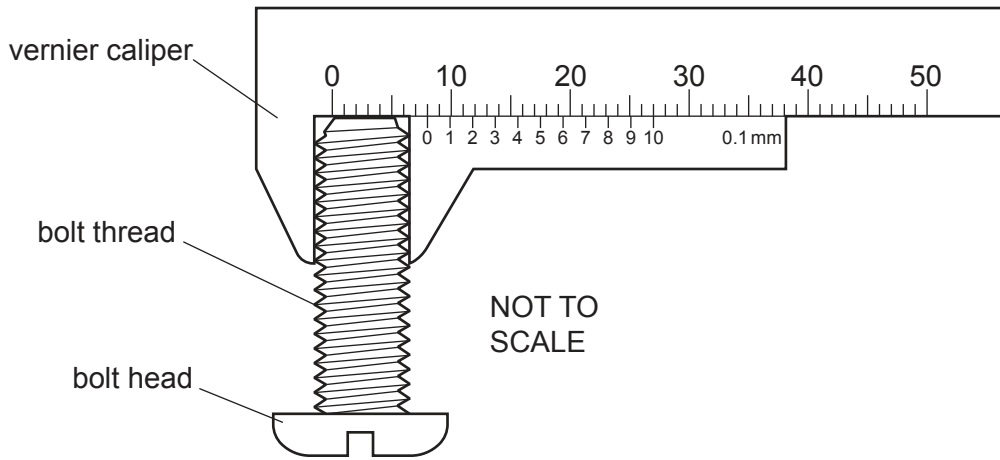

Fig. 4.1

(a) Determine the reading shown on the vernier scale in Fig. 4.1.

..... mm [1]

(b) Fig. 4.2 is a large diagram of the bolt, drawn to scale.

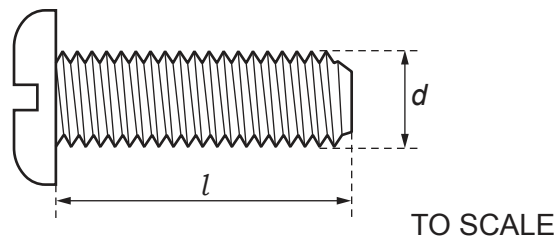

Fig. 4.2

(i) Use a ruler to measure the thread length l and the diameter d in Fig. 4.2.

R is the ratio of the length l to the diameter d .

Calculate R using the equation: $R = \frac{l}{d}$

$R =$ [1]

(ii) Use your answers in (a) and (b)(i) to determine the actual length of the bolt thread.

actual length = mm [1]

(c) Describe how to use a measuring cylinder to find the volume of the bolt.

.....

.....

.....

..... [2]

[Total: 5]

5 Chlorine, bromine and iodine are elements in Group VII of the Periodic Table.

(a) (i) State another name for the Group VII elements.

..... [1]

(ii) Define 'an element'.

.....
 [1]

(b) An atom of chlorine is represented by the symbol ${}_{17}^{35}\text{Cl}$.

Deduce the electronic structure of this atom of chlorine.

..... [1]

(c) Table 5.1 shows the colour and boiling points of some Group VII elements.

Table 5.1

element	chemical symbol	colour	boiling point / °C
chlorine	Cl	pale green	-34
bromine	Br	red	
iodine	I	black	184

(i) Describe the trend in colour as you go down Group VII.

..... [1]

(ii) Predict the boiling point of bromine.

..... °C [1]

(d) Aqueous chlorine reacts with aqueous sodium bromide.

Balance the equation for the reaction.

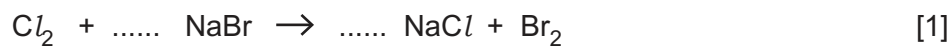

[Total: 6]

- 6 Fig. 6.1 shows a force of 200 N applied at the end of a wrench to tighten a bolt. The bolt acts as a pivot.

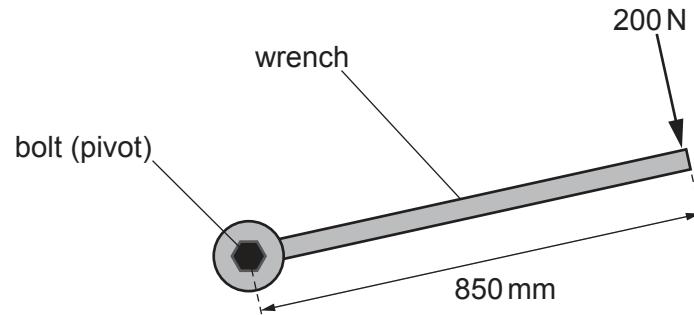

Fig. 6.1

- (a) Calculate the moment of the 200 N force about the centre of the bolt.

Give your answer in standard notation and state the unit.

moment = unit [3]

- (b) A different wrench has a weight of 5 N.

A small electric motor produces a power of 2 W to lift this wrench.

Calculate the height through which the motor lifts this wrench in 1.5 seconds.

height = m [4]

[Total: 7]

7 Fig. 7.1 shows the human alimentary canal and associated organs.

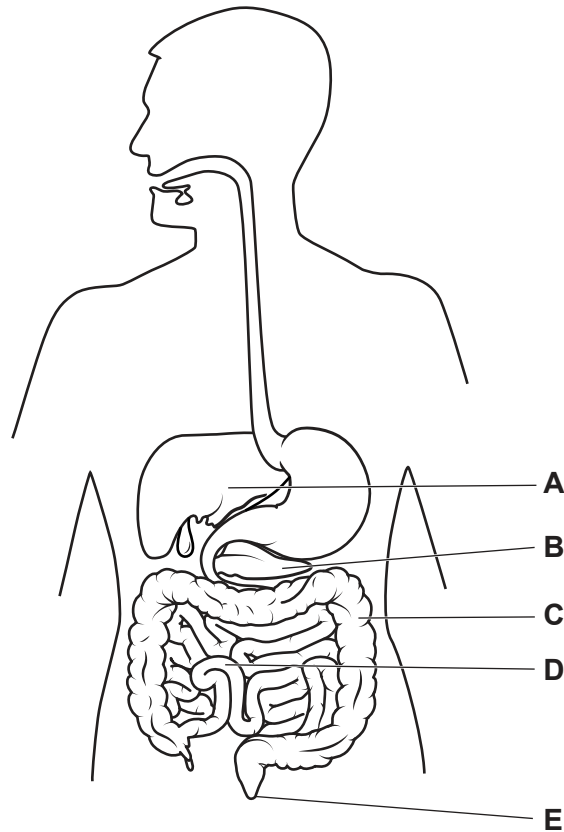

Fig. 7.1

Complete Table 7.1 by inserting the names and **one** function of each of the structures.

Table 7.1

label on Fig. 7.1	name of structure	one function of structure
A		produces bile
B	pancreas	
C	colon	
D		absorbs digested food
E	anus	

[5]

8 Fig. 8.1 shows the molecular structure of octene.

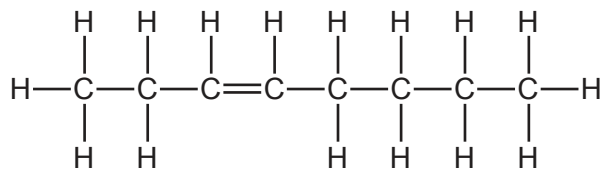

Fig. 8.1

(a) (i) Deduce the formula of octene.

..... [1]

(ii) Explain how the structure of octene shows that it is an unsaturated compound.

.....
 [1]

(b) Fig. 8.2 shows a chromatography experiment to test the purity of an organic compound.

This compound is soluble in ethanol.

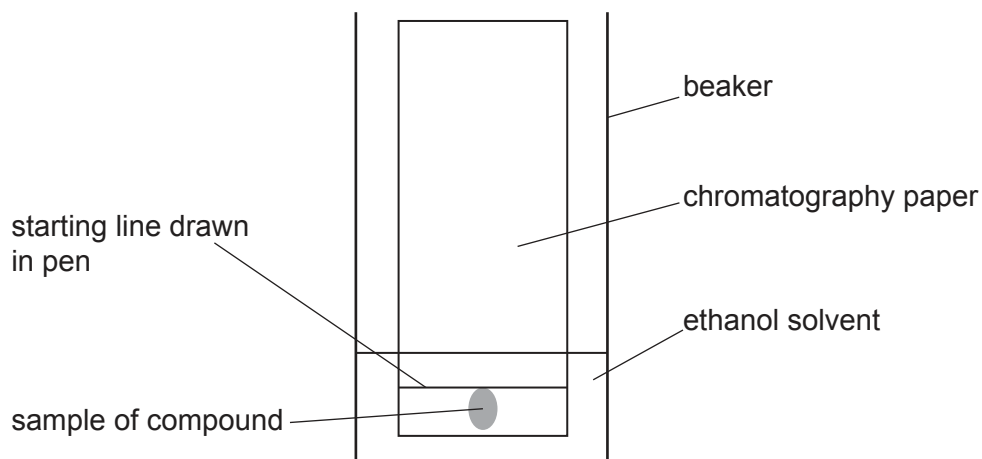

Fig. 8.2

(i) Suggest **two** errors in the experiment shown in Fig. 8.2.

error 1

error 2

[2]

(ii) Describe what is observed on the chromatogram if the compound is pure.

..... [1]

[Total: 5]

9 Fig. 9.1 shows a length of wire carrying a load. The wire is heated by a flame.

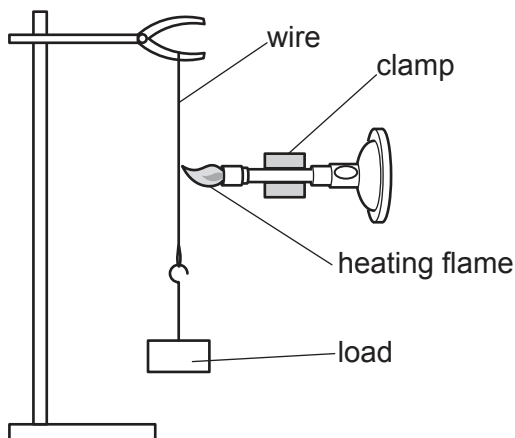

Fig. 9.1

(a) State the name of the process by which thermal energy is transferred through the wire.

..... [1]

(b) During heating, the load moves down 2 mm. The wire does not break.

Use ideas about particles to explain the changes in the wire that cause the load to move down.

.....

 [2]

(c) The wire glows brightly when it is hot.

Heat from the glowing wire is detected by a thermometer placed 5 cm to one side of the wire.

State the name of the process by which thermal energy from the glowing wire is transferred to the thermometer.

..... [1]

(d) The air above the heating flame is much hotter than the air below it.

Explain why.

.....
 [2]

[Total: 6]

10 The structures present in a flower each perform a specific function.

Draw **one** straight line from **each** structure to identify its function.

structure	function
anthers	attracts insects
carpels	produces ovules
petals	produces pollen
sepals	produces the testa
	protects the flower when forming

[4]

11 Hydrogen reacts with chlorine to form hydrogen chloride, HCl.

(a) Complete Fig. 11.1 to show the outer electrons in a molecule of hydrogen chloride.

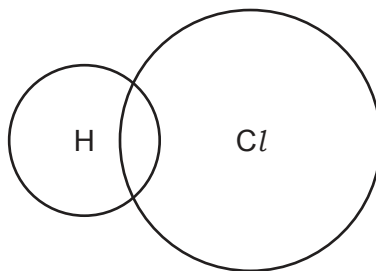

Fig. 11.1

[2]

(b) Fig. 11.2 shows three reactions of hydrogen.

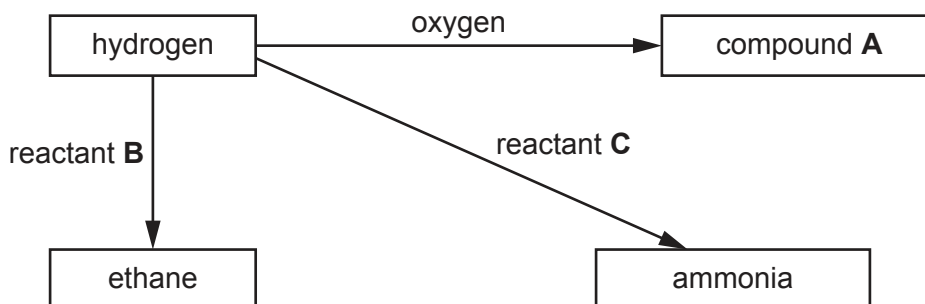

Fig. 11.2

Identify compound **A** and reactants **B** and **C**.

compound **A**

reactant **B**

reactant **C**

[3]

(c) Define oxidation in terms of what happens to the hydrogen in a reaction.

.....

..... [1]

[Total: 6]

- 12 Fig. 12.1 shows two wires of different metals that are twisted together and placed in a beaker of melting ice.

This produces a small voltage which can be measured using a voltmeter.

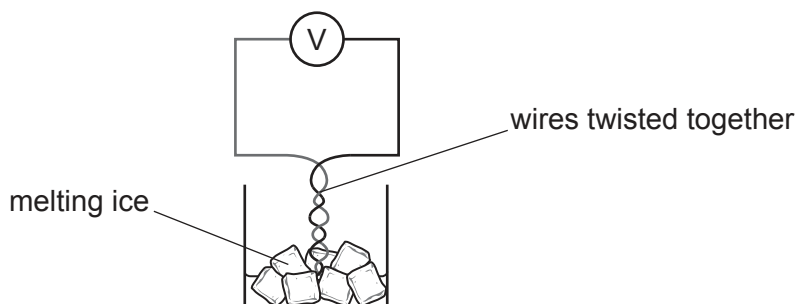

Fig. 12.1

The voltmeter is adjusted so that the reading on the scale is 0.0 mV when the twisted wires are in the melting ice.

The voltage is then measured with the wires placed first in boiling water and then in a hot flame.

The measurements are shown in Table 12.1.

Table 12.1

	voltmeter reading / mV
melting ice	0.0
boiling water	5.4
hot flame	54

- (a) (i) State the temperature difference between the temperature of melting ice and the temperature of boiling water.

temperature difference = °C [1]

- (ii) Use the results in Table 12.1 and your answer to (a)(i) to predict the temperature of the hot flame.

temperature of the hot flame = °C [1]

- (b) One volt (1V) is equal to one joule per coulomb (1 J/C).

Explain what is meant by the term 'joule per coulomb'.

.....
 [2]

[Total: 4]

13 Fig. 13.1 shows a diagram of a section through a leaf.

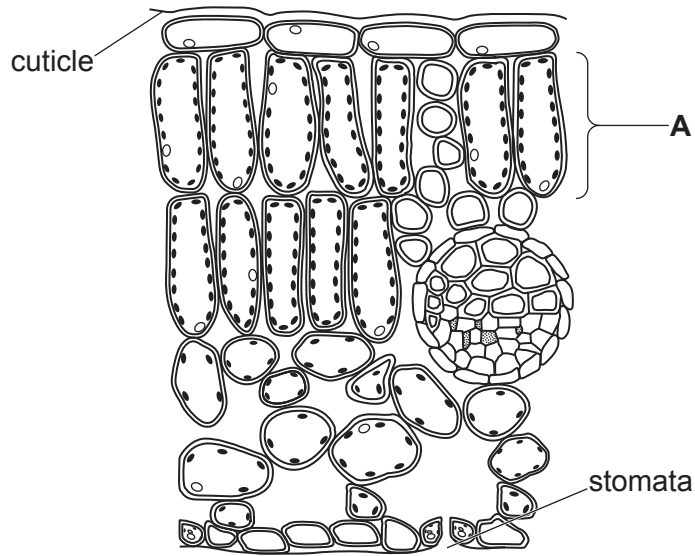

Fig. 13.1

(a) State the name of the layer of cells labelled **A** on Fig. 13.1.

..... layer [1]

(b) The cells in layer **A** contain many chloroplasts.

Describe the function of chloroplasts in a plant.

.....
.....
.....
..... [2]

(c) State the function of the cuticle.

.....
..... [1]

- (d) Gases diffuse into and out of a leaf through the stomata.

Complete Table 13.1 with the name of **one** gas that moves into a leaf and **two** gases that move out of a leaf during bright daylight.

Table 13.1

gas diffusion during bright daylight	
gas moving into a leaf	gases moving out of a leaf

[3]

[Total: 7]

14 Electrons in atoms are arranged in shells.

(a) State the relative charge and the relative mass of an electron.

relative charge

relative mass

[2]

(b) Table 14.1 shows the electronic structures of five different elements **V**, **W**, **X**, **Y** and **Z**.

The letters are not the symbols of the elements.

Table 14.1

element	electronic structure
V	2
W	2,1
X	2,8,6
Y	2,8,8,7
Z	2,8

Use the letters **V**, **W**, **X**, **Y** or **Z** to complete the following sentences.

Each letter can be used once, more than once or not at all.

The element that forms an ion with a charge of -2 is

The element that is a noble gas is

The element that is found in period 1 of the Periodic Table is

The element that is a metal is

[4]

[Total: 6]

15 Fig. 15.1 shows a simple circuit.

The lamp is lit and there is a reading of 0.2 A on the ammeter.

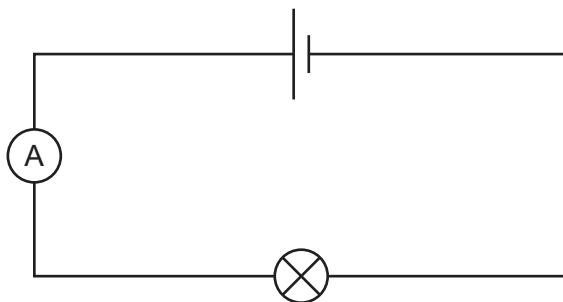

Fig. 15.1

A variable resistor is now placed in parallel with the lamp.

The resistance of the variable resistor is adjusted until the reading on the ammeter is 0.4 A.

(a) Determine the current in the variable resistor.

current = A [1]

(b) (i) The resistance of the lamp is $3.0\ \Omega$.

Calculate the e.m.f. of the cell.

e.m.f. = V [2]

(ii) The potential difference across the variable resistor in parallel with the lamp is the same as the potential difference across the lamp.

Determine the resistance of the variable resistor.

resistance = Ω [1]

[Total: 4]

16 State **three** ways in which human immuno-deficiency virus (HIV) can be spread.

- 1
-
- 2
-
- 3
-

[3]

17 When dilute sulfuric acid is added to excess magnesium, the temperature of the reaction mixture increases.

(a) Complete the word equation for the reaction between magnesium and sulfuric acid.

magnesium + sulfuric acid \rightarrow + [2]

(b) Suggest a piece of apparatus that could be used to remove the excess magnesium at the end of the reaction.

..... [1]

(c) State the name of the type of reaction that gives out heat energy.

..... [1]

(d) Describe what happens to the pH of the reaction mixture during the reaction.

.....

..... [1]

[Total: 5]

18 (a) Fig. 18.1 shows a permanent magnet on a float on the surface of a bowl of water.

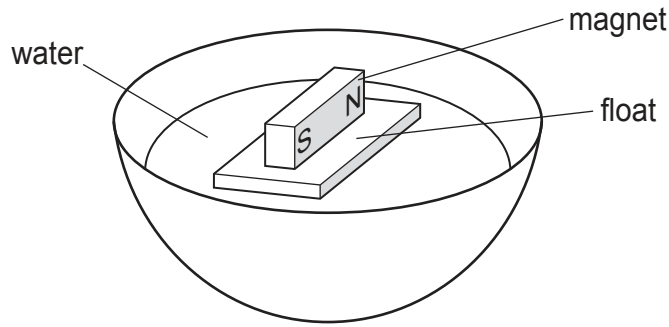

Fig. 18.1

A student slowly rotates the magnet and float on the surface of the water to the position shown in Fig. 18.2.

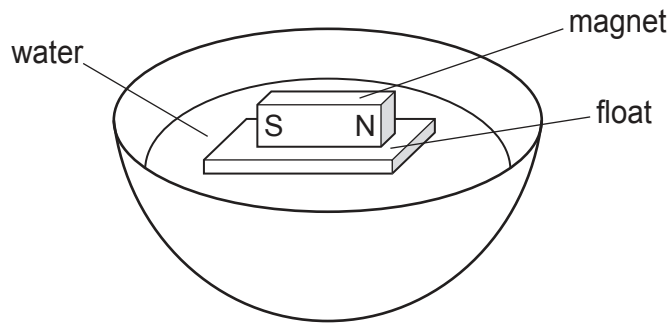

Fig. 18.2

The student releases the magnet and float and they slowly rotate back to the original position shown in Fig. 18.1.

Use ideas about the properties of magnets to explain why the magnet and float return to the original position.

.....
.....
..... [2]

(b) Describe **two** ways that an electromagnet is different from a permanent magnet.

1
.....
2
.....
[2]

[Total: 4]

19 Some words about atoms are listed below.

electrons element neutrons
nucleons nucleus nuclide protons

Use words from the list to complete the following sentences about the information given in Fig. 19.1.

Each word may be used once, more than once or not at all.



Fig. 19.1

The type of notation shown in Fig. 19.1 is notation.

A minus **Z** gives the number of

Z minus the number of is equal to zero.

[3]

BLANK PAGE

Permission to reproduce items where third-party owned material protected by copyright is included has been sought and cleared where possible. Every reasonable effort has been made by the publisher (UCLES) to trace copyright holders, but if any items requiring clearance have unwittingly been included, the publisher will be pleased to make amends at the earliest possible opportunity.

To avoid the issue of disclosure of answer-related information to candidates, all copyright acknowledgements are reproduced online in the Cambridge Assessment International Education Copyright Acknowledgements Booklet. This is produced for each series of examinations and is freely available to download at www.cambridgeinternational.org after the live examination series.

Cambridge Assessment International Education is part of Cambridge Assessment. Cambridge Assessment is the brand name of the University of Cambridge Local Examinations Syndicate (UCLES), which is a department of the University of Cambridge.

